



MARINE LIGHTING

## USER MANUAL



Xenon searchlight  
electrical remote control

Type reference

**IM400RCX**

Manufactured by:

**IMAX B.V.**  
[www.imaxtrading.net](http://www.imaxtrading.net)

Distributor:

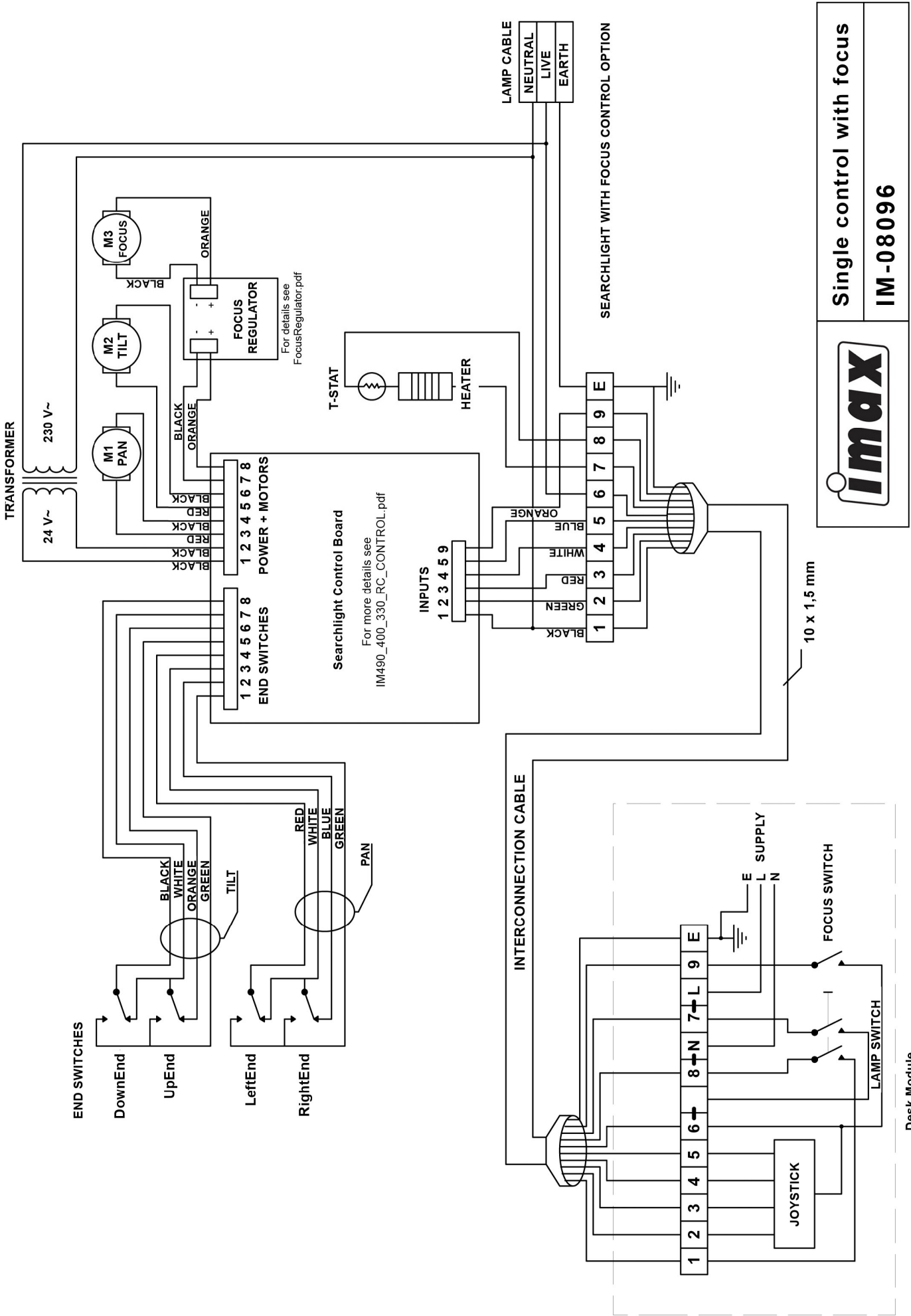

Single control with focus

IM-08096



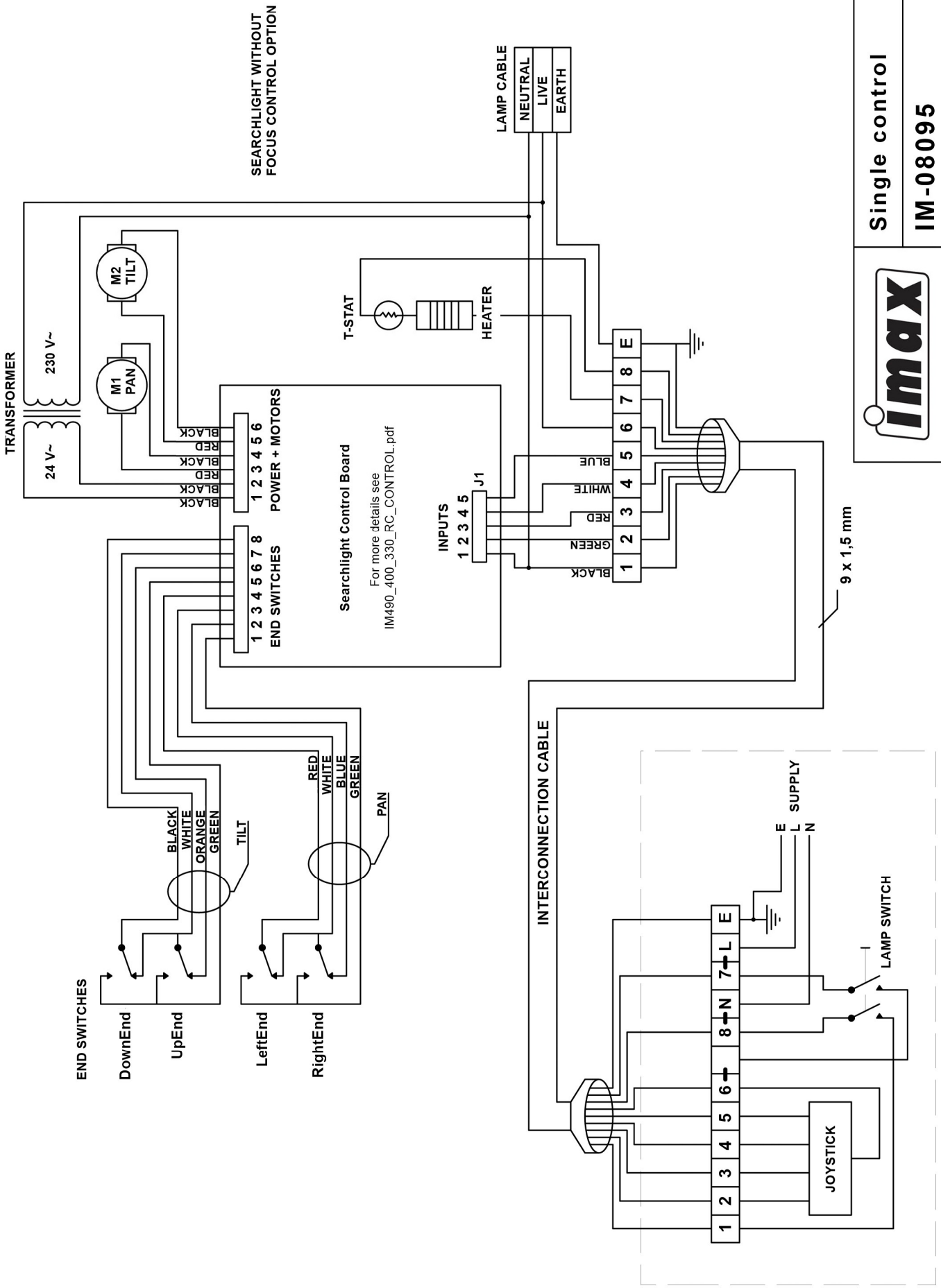

Single control  
IM-08095



# CONTENTS

- 1 - Introduction
- 2 - Safety Precautions
- 3 - Technical Information
- 4 - Pre-Installation Instructions
- 5 - Electrical Installation
- 6 - Diagrams and Assembly drawings
- 7 - Operating Instructions
- 8 - Fault Finding
- 9 - Maintenance and Servicing
- 10 - Spare Parts List
- 11 - Test Certificate and Serial Number

**Please read and understand this manual before you install the equipment.**

We are very pleased that you specified this IMAX product.

When we designed the product our aim was that it should be to the entire satisfaction of the user.

Therefore, and to ensure optimum performance and a long trouble free service life, IMAX manufactured the Product to the highest engineering standards.

The design of the product is based on many years of experience in the field of Marine Lighting, it is made to withstand the environmental conditions in both offshore and inshore.

In order to maintain the quality standard of the equipment, we strongly recommend to use original IMAX spares whenever any part should be replaced, just to ensure and to prolong service life and performance.

A spare parts list is attached to this manual.

Always quote Product Serial Number in case there is a need to contact IMAX B.V. regarding the equipment.

**To create a safe working environment and safety of the user, the instructions given hereunder must be strictly adhered to :**

**ATTENTION : In order to prevent personal injury or damage to the searchlight, when unpacking or manoeuvring the unit into its final position, suitable lifting points must be used.**

**!**  
**Prevent rain, snow, condensation and water droplets from contacting the lamp as this may cause bulb failure and possible shattering.**

**!**  
**Quartz halogen bulbs run with a high pressure in excess of atmospheric.**  
**Whilst the construction is inherently strong, there is a slight risk of the bulb shattering.**

**!**  
**Never look directly into an illuminated searchlight as this may cause severe damage to eyesight. If it is necessary to inspect a lamp whilst in operation, always wear suitable protective goggles.**

**!**  
**Should it be necessary to examine the lamp with the front bezel removed, always use a protective shield and wear goggles to ensure a safe working environment.**

**!**  
**Searchlights get very hot. Never touch the unit when lit. Always allow it to cool down for 15 to 20 minutes after it has been switched off.**

**!**  
**Never place anything on or cover the searchlight when in use.**

**!**  
**Ensure the lamp has cooled sufficiently before removal.**

**!**  
**If excessive force appears to be necessary to remove the lamp, the equipment should be inspected by a competent person or contact the manufacturer**

**!**  
**When breaking a lamp for disposal, care must be taken to ensure the glass fragments are safely contained. This operation must be performed out of doors in free air. In all circumstances refer to the lamp manufacturer instructions packed with the lamp.**

**!**  
**Due to the vast range of lamps available it may appear possible that more powerful lamps can be used in the equipment than it was designed for. Even when the unit physically accept a higher wattage or voltage lamp, this substitution is not recommended and it is dangerous. This action will also void any warranties on the equipment.**

**Always refer to the lamp manufacturers technical data when dealing with lamps.**

## 3 - TECHNICAL INFORMATION

The searchlight IM490RC has the following features :

- All marine grade materials and fixings
- Parabolic silvered glass mirror/reflector
- Epoxy powder coatings
- Pan movement 360°
- Tilt movement +30° to -30°
- Pan speed 12°/sec
- Tilt speed 2.4° /sec
- Operating temp. -30° to +70°
- Remote focus facility (optional)
- Internal thermostatically controlled heater (75Watt)
- Toughened heat resistant front glass

Optical data for the IM490RC :

	<u>1000W T/H</u>	<u>2000W T/H</u>
• Supply voltage	115/230V	115/230V
• Peak Beam Candle Power	2.098.000 cd	2.748.300 cd
• Range	1.448 mtr	1.657 mtr
• Divergence	5° – 8°	5° – 8°
• Operational temperature	-30 to + 70° C	-30 to + 70° C

In order that the searchlight operates correctly it is imperative that competent personnel are responsible for the installation, operating and servicing of this equipment, Failure to adhere to this advice may cause premature failure or incorrect operation of the searchlight, which may damage the equipment or cause personal injury.

In case the equipment is to be stored for a relatively long period of time, care must be taken for a clean and dry environment.

In case the unit has been in storage for several months it is advised to conduct a routine maintenance check before it is installed in its definite position.

**SAFETY :**

Do not connect the searchlight to an electrical supply before being installed.

Please take care of a safe working environment to avoid damage and personal injury.



The electrical installation of the equipment should be performed by competent personnel in accordance with current Electrical Installation Rules and Standards.

It is essential that full operating voltage is applied to the lampholder in order to obtain maximum performance of the lightsource.

Method of Electrical Connection :

**!! Disconnect the supply before working on the electrical system**

**!! The electrical supply must be properly fused**

**!! To obtain full voltage supply on the lampholder terminals, provisions must be made in cables of a suitable diameter.**

**!!! THE EQUIPMENT MUST BE EARTHED**

Drawing number :

IM08095 - Wiring diagram, single panel control

IM08096 - Wiring diagram, single panel control + optional focus control

IM08097 - Wiring diagram, multi panel control with Electronic Interlocking

IM400-111 Outline Joystick Control Panel

General outline IM490RC

## 7 - OPERATING INSTRUCTIONS

**The searchlight is designed for use outdoors.  
When in use never cover the searchlight or lay anything on it  
because this will create a serious possibility of fire or other hazard.**

**The searchlight is electrical remote controlled by an 8-position joystick controlpanel.  
Two movements, e.g. down and left, or up and right, can be performed simultaneously.**  
When the beam is in the required position release the joystick which will return in the centre position.

As an optional extra the searchlight can be fitted with remote focus control.  
To operate it push the button on the controlpanel.. The beam will move continuously from spot to flood and reverse.  
Release the push button when the required beam is achieved.

The thermostatically controlled heater in the motor unit must be permanently connected to the supply voltage. The 75 Watt heater will automatically be switched off when the dew point temperature is reached.

Any modification, addition of conversion of the equipment should not be undertaken without consulting the Manufacturer.

To put the searchlight to work :

Please observe the following precautions.

! Be sure that the searchlight is isolated from the supply before changing the lamp

! The envelope of a lamp is made in glass or quartz, which materials are inherently fragile, please bear this in mind when handling lamps.

! When handling lamps which have been taken from the packing material, eye protection should be worn.

! Check the lampholder contacts to ensure that they are clean and free from dirt and/or corrosion. Corroded areas must not be cleaned by sanding or filing because this will reduce the conduction surface which in turn may cause the lamp to overheat.

! When fitting the lamp do not apply mechanical stress on the quartz bulb. Do not bend or twist it.

! When the lamp warms up it must be able to expand. Mechanical stress must be avoided to the fused quartz envelope.

! The lamps is provided with a protective jacket. Before that jacket is removed it is strongly advised to wear suitable protection e.g. gloves with wrist protection, face mask.

! Do not touch the quartz envelope with bare hands. Fingerprints will makes the glass cloudy and cause loss of light. Also it may cause recrystallisation thus weaken the bulb material. If the bulb has been inadvertently touched fingerprints can be removed with methylated spirit and a clean tissue. The bulb should then be wiped with distilled water.

**ALWAYS WEAR MASK AND GLOVES WHEN HANDLING LAMPS**

Test 1.

LAMP CIRCUIT.

Check condition of the lamp and lampholder . Replace if worn out.

If lamp is in good condition, check supply.

Junction box terminals 1 + 6 must read 230V \*

Test 2

PAN and/or TILT CIRCUIT.

If one or more functions fail :

Open junction box at the back of the searchlight

Check whether supply voltage and movement commands arrive on terminals :

7 + 8 Permanent supply voltage 230 V \*

6 + 2 Pan movement right

6 + 3 Pan movement left

6 + 4 Tilt movement up

6 + 5 Tilt movement down

If supply voltage and/or any of the commands fails, check control panel and connections between the control panel and the searchlight. Restore if necessary.

When supply voltage and commands are correct, open searchlight motor housing from the bottom. Check input 230 V \* and 24Vac output on the transformer.

Measure 24Vac input on terminals 1+2 on motor controller junction J3.

If 24Vac on the input is present, output voltage on terminals 3+4 for pan motor and 5+6 for tilt motor should read **24Vdc** when energised according to above mentioned schedule in test 2. If no **24Vdc** on the output replace the motor controller.

If the **24Vdc** is present, disconnect motor(s) and test separately.

Test 3.

LIMIT SWITCH CIRCUIT

With all four switches in the normally closed mode :

Motor controller junction J2 readings :

terminals 1+2 =  $\infty \Omega$  (

terminals 2+3 = **0  $\Omega$**  ( Pan movement

terminals 2+4 = **0  $\Omega$**  (

terminals 5+6 =  $\infty \Omega$  (

terminals 6+7 = **0  $\Omega$**  ( Tilt movement

terminals 7+8 = **0  $\Omega$**  (

Test 4.

HEATER ELEMENT

Junction box terminals 7+8 should read 230V\* permanently.

To avoid condensation in the motorhousing it is important that the heater is continuously energised.

\* or 110V in case

## **9 - MAINTENANCE**

**To prolong the service life and to ensure the maximum performance of the searchlight, we recommend the following maintenance guidelines :**

**Dirt on front glass and/or mirror reflector will result in a considerable loss of light. Before every voyage the equipment should be checked on these points as well as on good working of the lamp.**

**Periodical maintenance is recommended at least once every three months.**

**Before opening the searchlight for cleaning and/or inspection of the interior the supply must be disconnected.**

**Procedure :**

**Remove front glass and bezel assembly**

**Inspect the lampholder, ensure that it is free from dirt and corrosion.**

**Inspect the lamp. The quartz envelope must be bright and clear.**

**Replace if necessary.**

**Check all seals and rubber mountings of the mirror reflector.**

**Replace if necessary.**

**Check earthing point for conductivity**

**Check small ventholes in the bottom to be open**

**Check lamp supply cable on wear and tear.**

**After the inspection : Clean frontglass inside and outside, and clean the mirror reflector with a proprietary glass cleaner. Cleaning the mirror reflector does not harm the silvering because the silver layer is on the back of the glass.**

**Finally : Test searchlight for full working for 20 odd minutes.**



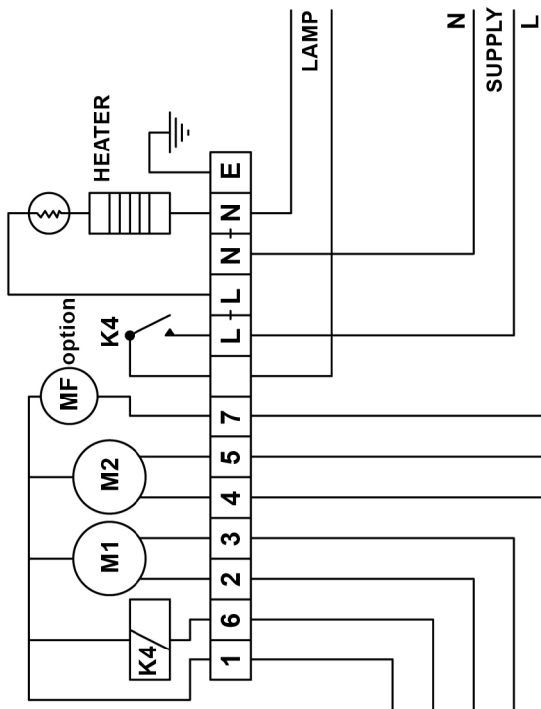

Focus control is an option  
if the option is not used, wire 7 is not applicable

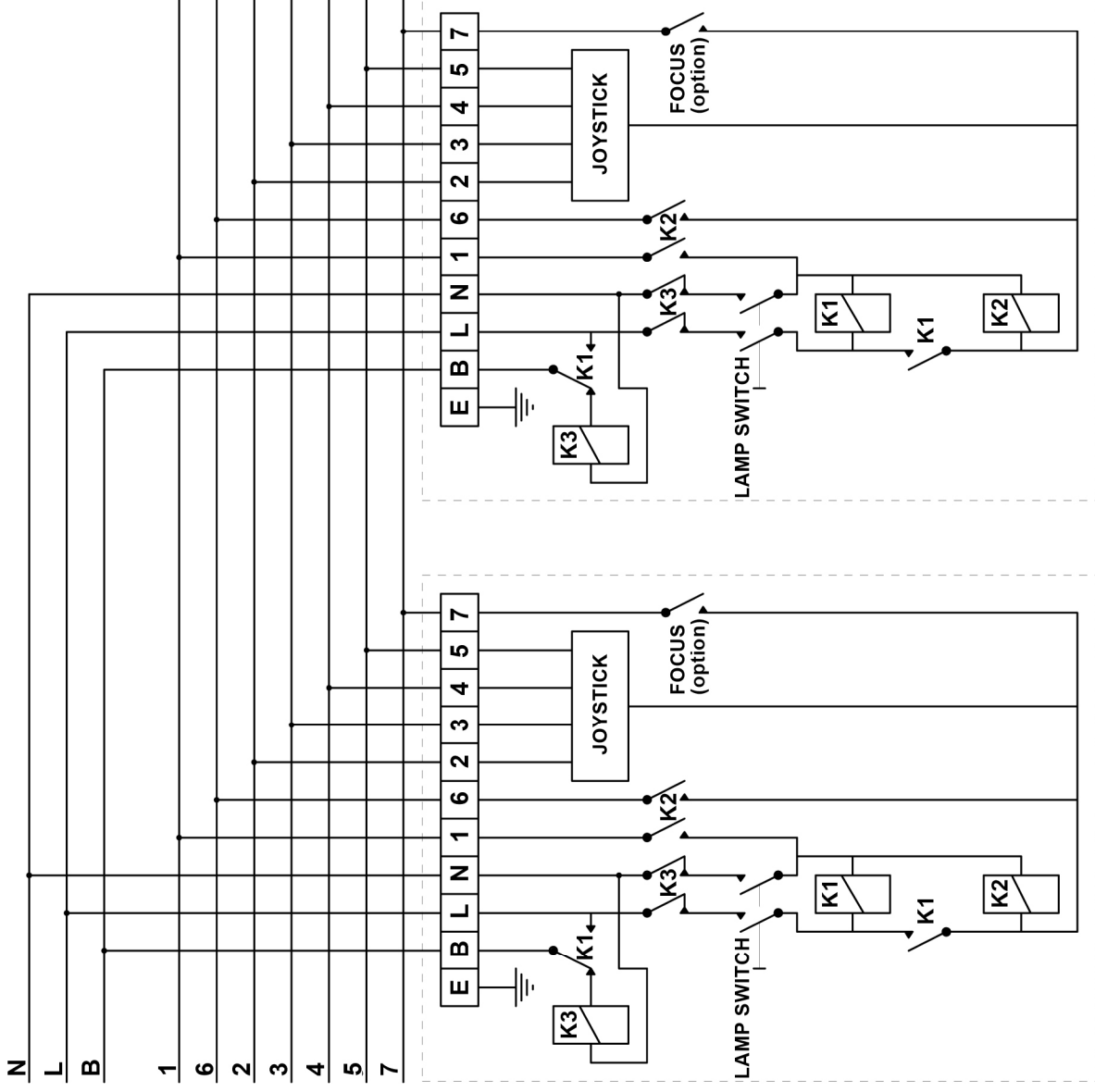



Multi control
IM-08097

1 2 3 4

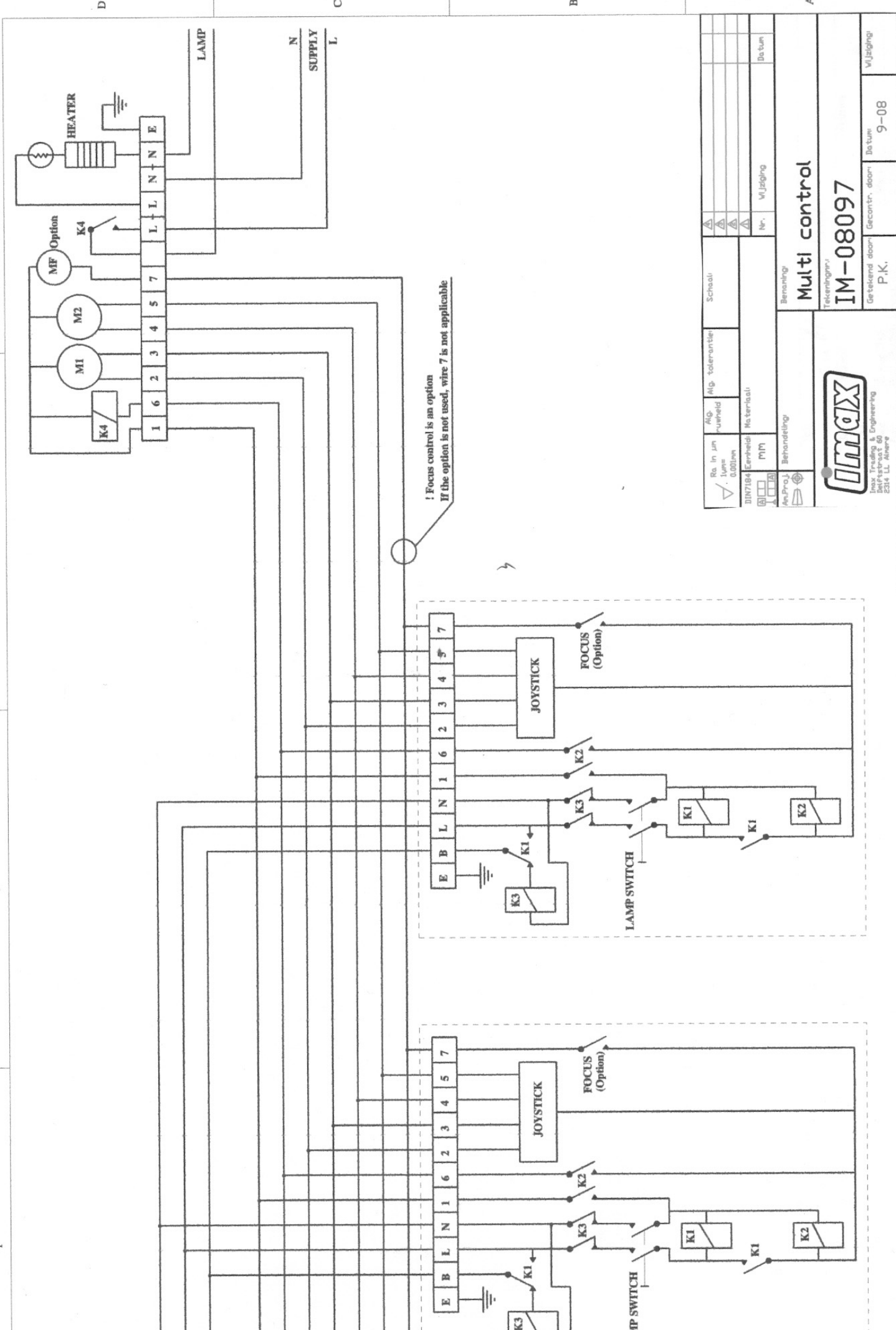

! Focus control is an option  
If the option is not used, wire 7 is not applicable

Ra in $\mu$ m Type 0.001mm	Alig. tolerantie u-ruwheid	Schaali	
0107184	Na materiaal		
M/M		Nr.	V.Jaiging
BeProJ	Behandeling		De tun
Benaming			
<b>Multi control</b>			
Telefoonnr. <b>IM-08097</b>			
Gefabriceerd door		Doetun	V.Jaiging
P.K.		9-08	



1 2 3 4



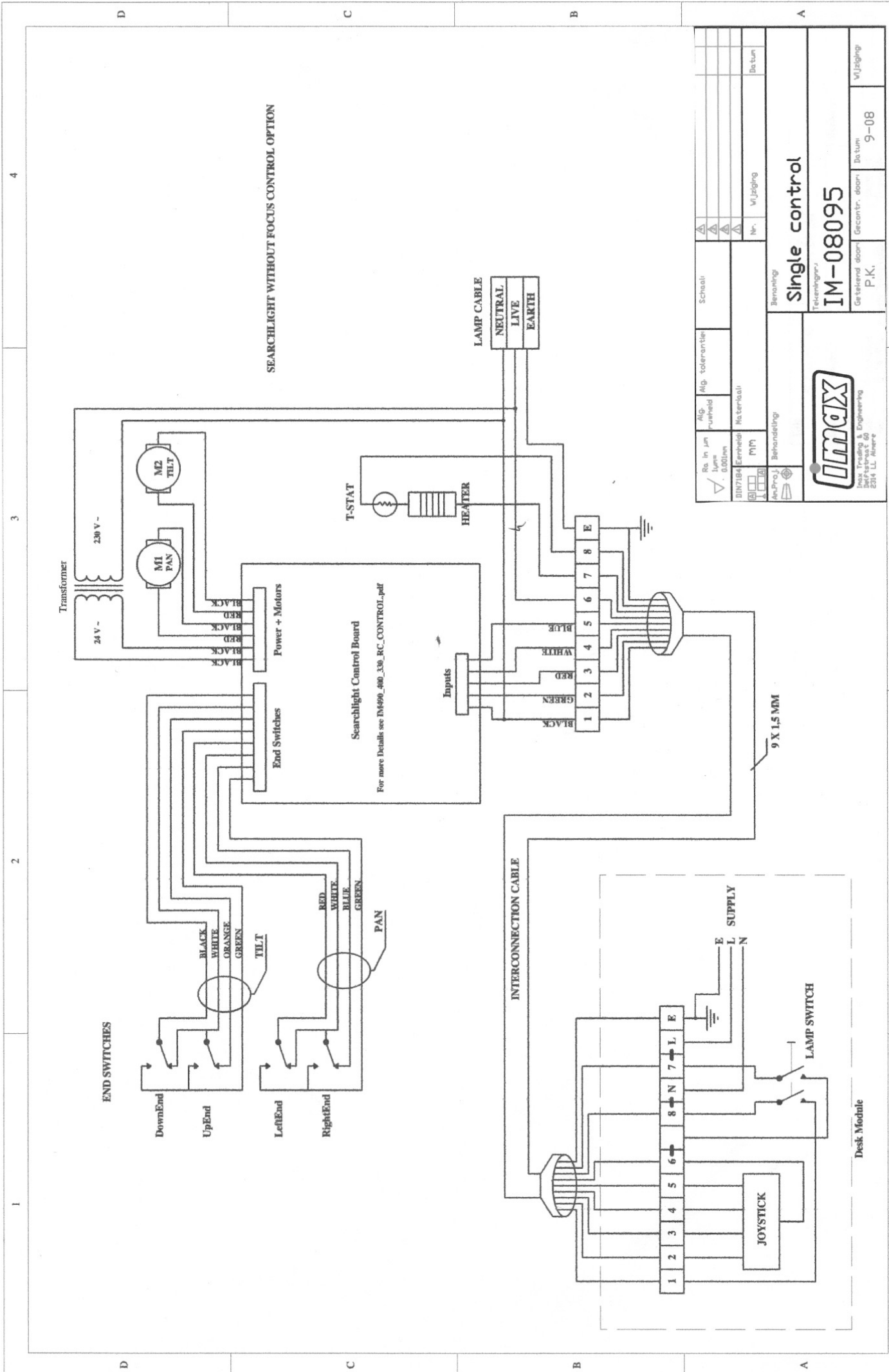

Ra In jun Type 0.001mm	Alg. - furnished	Alg. -tolerantie	School	Nr. Vrijdag Datum
DIN7884 Eisenstaaf	Material	M1	Behandelings	Benaming <b>Single control</b> <b>IM-08095</b> Geleverd door P.K.
			Datum 9-08	Vrijdag
Imax Trading & Engineering Bredastraat 60 5211 LL Almere				

4

3

2

1

4

3

2

1

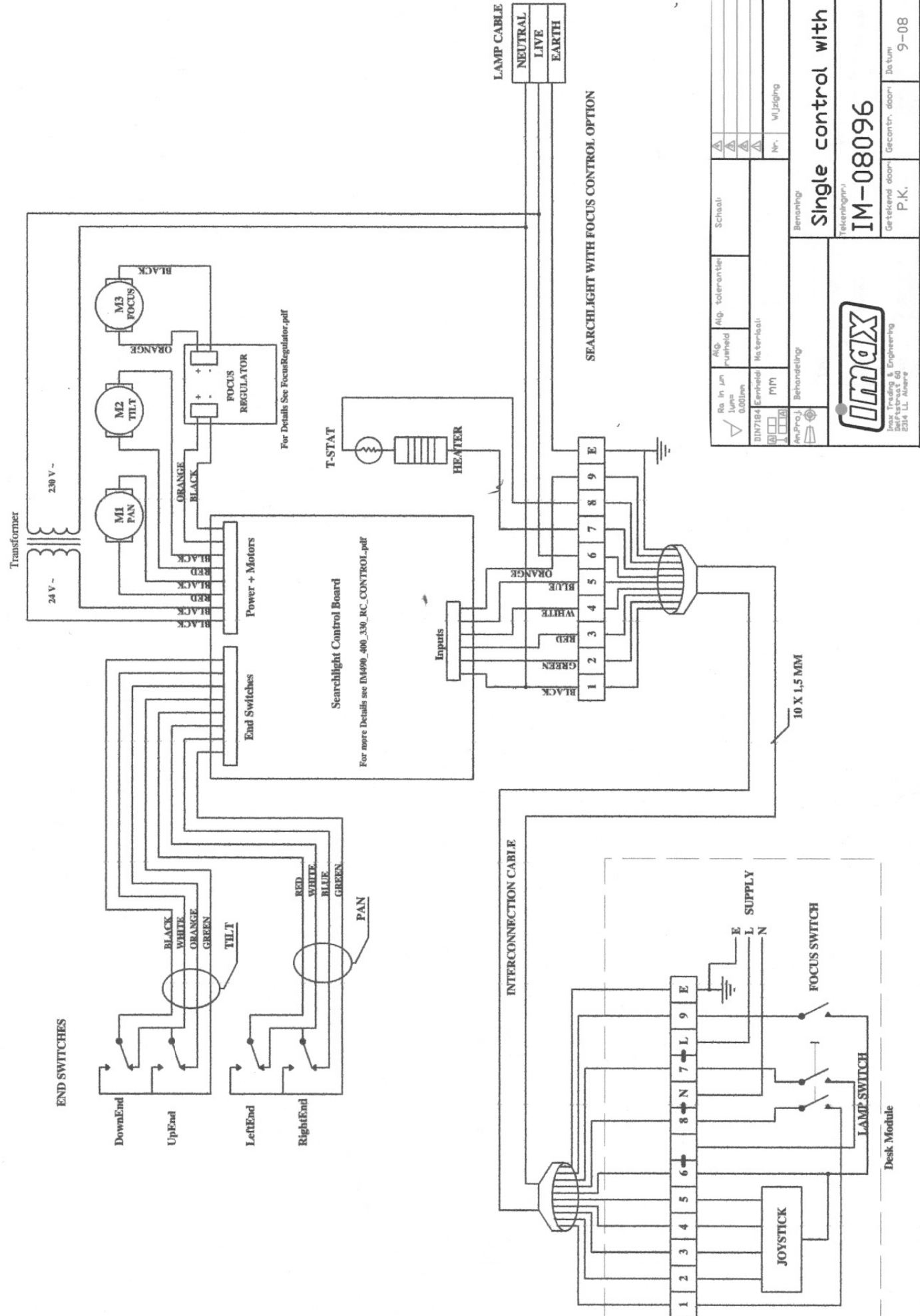

For Details See FocusRegulator.pdf

For more Details see IM400\_400\_330\_RC\_CONTROL.pdf

SEARCHLIGHT WITH FOCUS CONTROL OPTION

Ro in Jun	Alg. tolerantie	School	
Luys	ruwheid		
0.001mm	Na terhaal		
DIN7184	EMH	Nr.	Vliding
	Behandeling		Datum
Benaming			
<b>Single control with focus</b>			
<b>IM-08096</b>			
Getekend door: P.K.		Datum: 9-08	
Vliding		Vliding	



Imax Trading & Engineering  
Belfortstraat 60  
2314 LL Almere

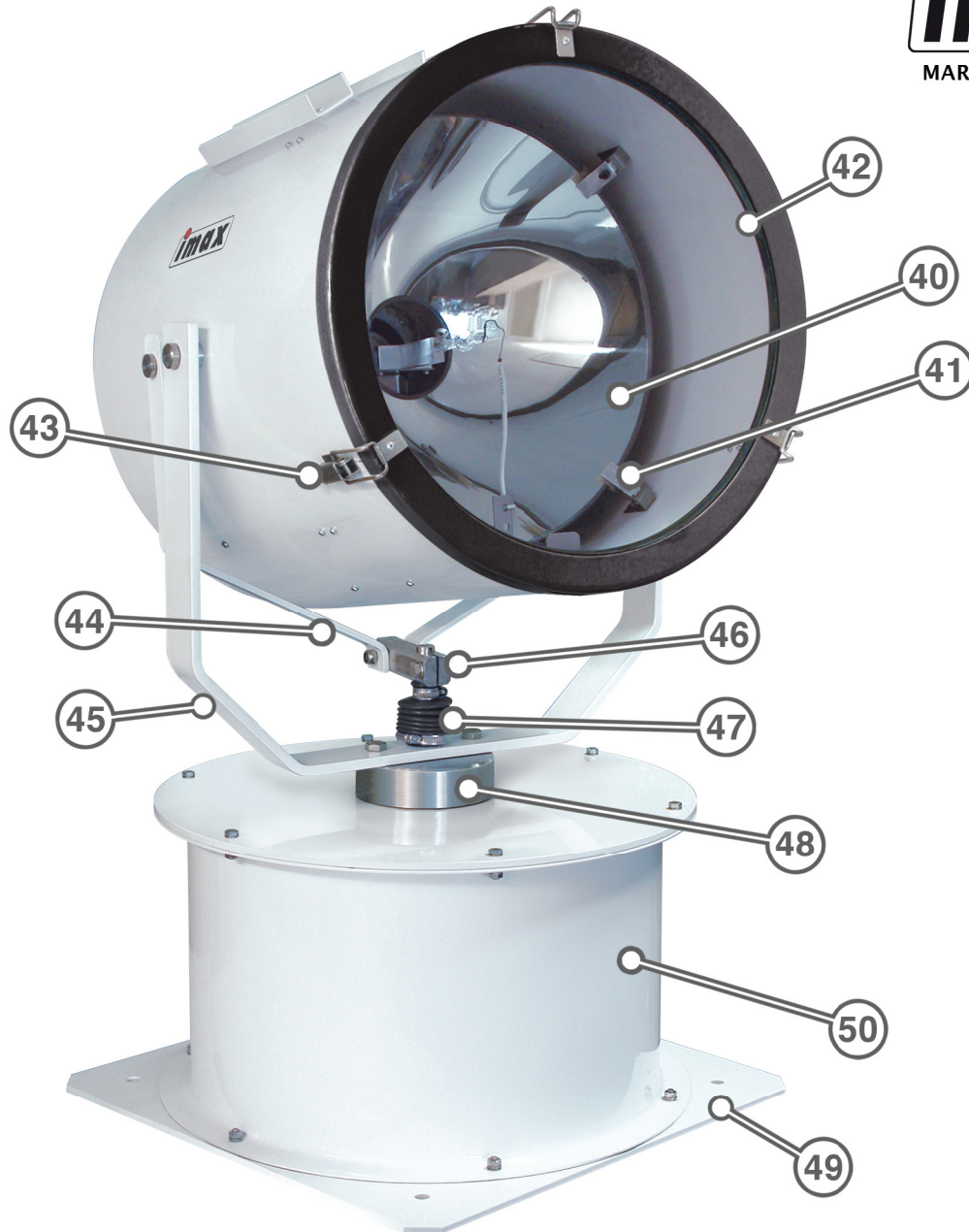

item	partnumber	description:
40	4004001	Mirror/reflector Xenon
41	9004100	Mirror fixing clamps, set
--	9004101	Mirror fixing cushions, set, silicon rubber
42	4004200	Frontrim assembly
--	4004201	Gasket, frontglass
--	4004202	Frontglass
43	9004300	Catches, frontrim
44	4034400	Fork set, tilt
45	4034500	Fork, main
--	9004501	Bearing bushes, main fork
46	9004600	Link
47	9004700	Bellow, rubber
48	5004800	Top-bearing
49	5004900	Mounting plate
50	5005000	Motor housing

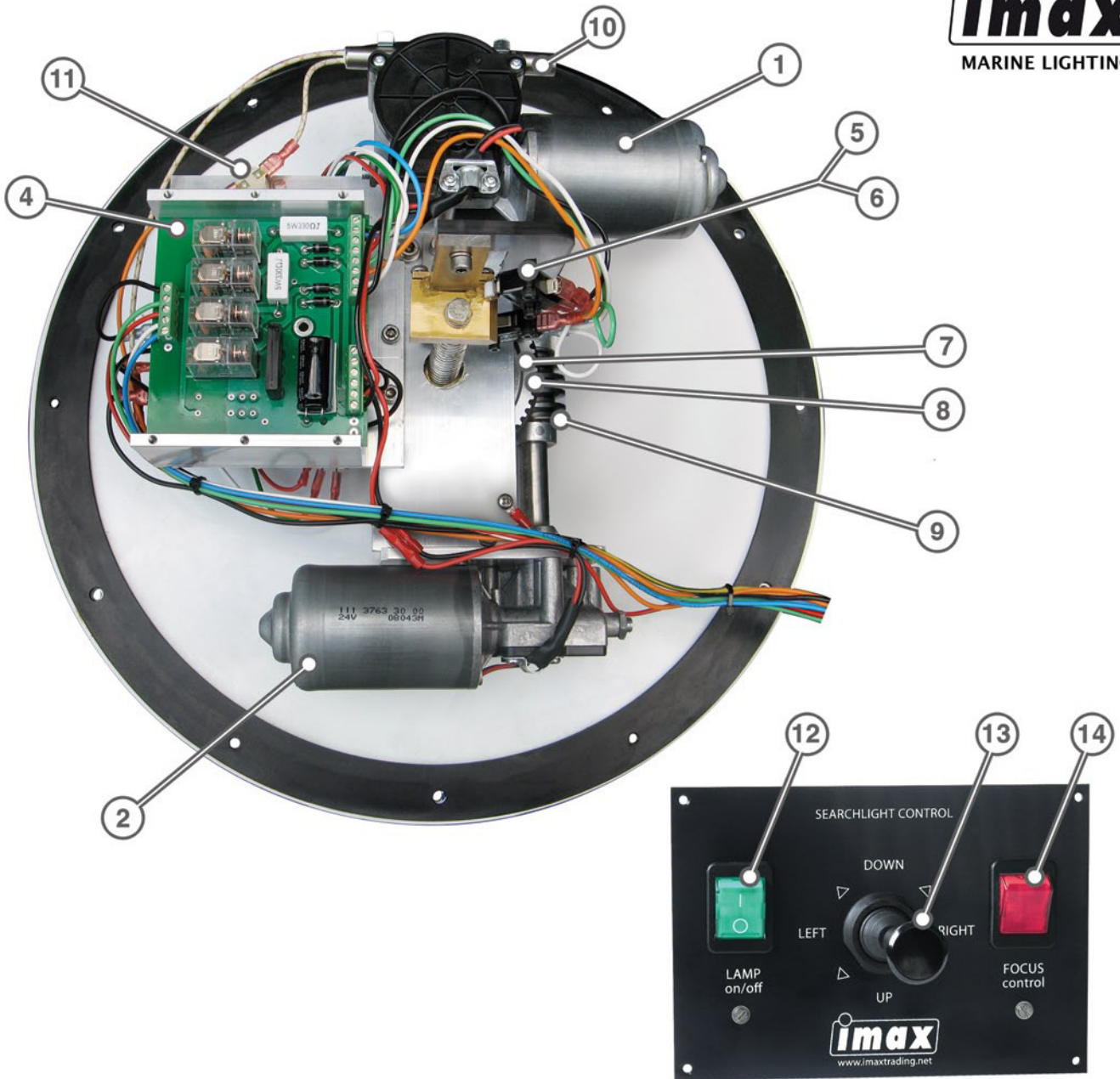

item	partnumber	description:
1	5000100	Motor, pan
2	5000200	Motor, tilt
4	5000400	Motor controller
5/6	5000500	Limitswitches, pan & tilt
7	5000700	Pulley, timing belt
8	5000800	Belt
9	5000900	Worm spindle
--	5000901	Worm wheel
10	9001000	Heater element
11	9001100	Thermoswitch
12	9001200	Switch - main
13	9001300	Joystick
14	9001400	Switch - focus (optional)
--	9001500	Terminal block



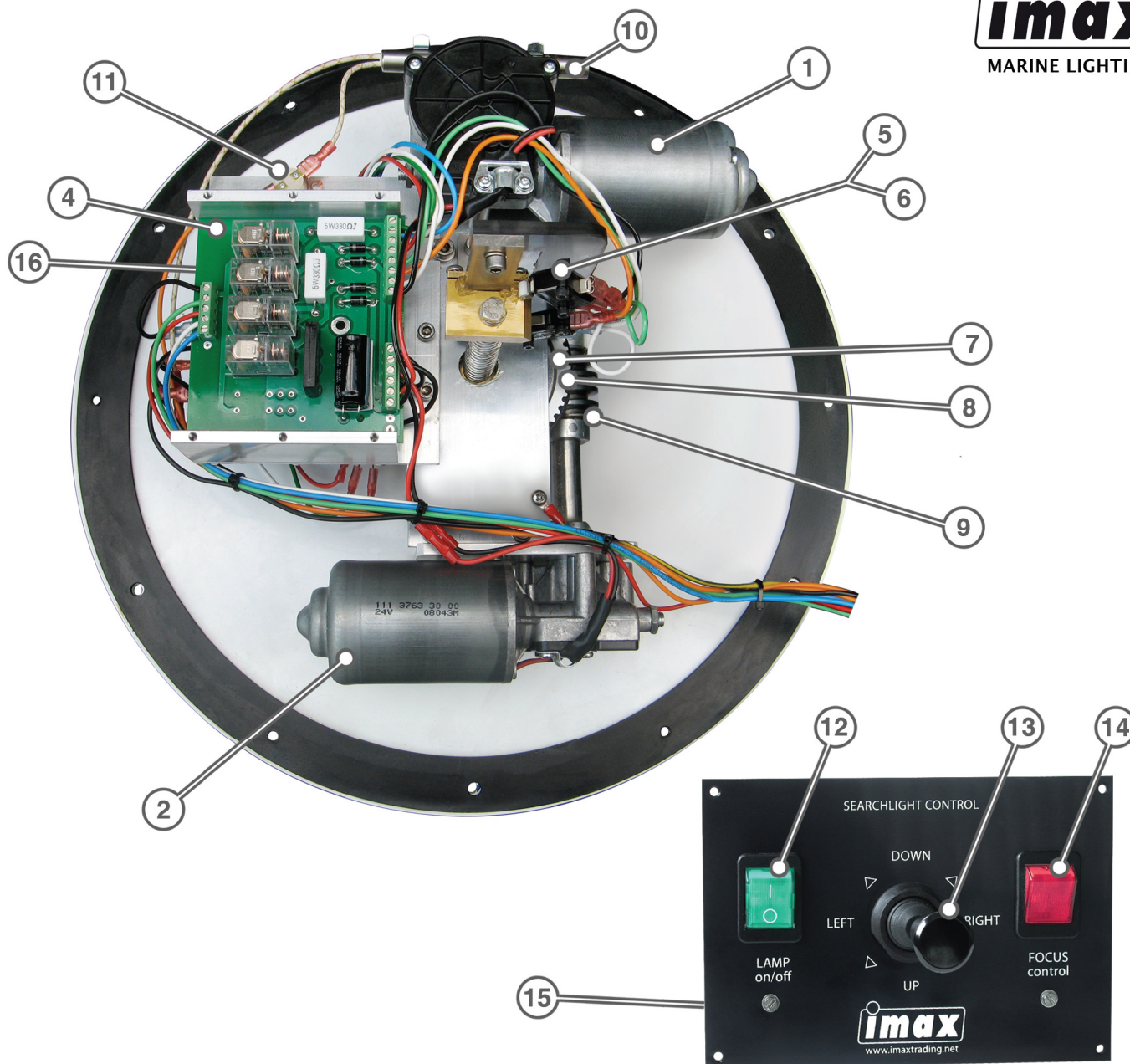

item	partnumber	description:
1	5000100	Motor, pan
2	5000200	Motor, tilt
4	5000400	Motor controller
5/6	5000500	Limitswitches, pan & tilt
7	5000700	Pulley, timing belt
8	5000800	Belt
9	5000900	Worm spindle
--	5000901	Worm wheel
10	5001000	Heater element
11	5001100	Thermoswitch
12	9001200	Switch - main
13	9001300	Joystick
14	9001400	Switch - focus (optional)
15	9001500	Terminal block
16	5001600	Transformer 230V-24V

