

IM350 RC

IMAX

SEARCHLIGHTS



IMAX Searchlights:

- **STAINLESS STEEL CONSTRUCTION**
- **SUPERB OPTICS**
- **POWERFUL LONGRANGE BEAM**
- **ELECTRICAL REMOTE CONTROL**
- **LOW MAINTENANCE**
- **DURABILITY**

The design of IMAX Searchlights is based on many years of experience and extensive research in the field of professional Marine lighting.

Carefully selected materials are used to ensure maximum performance, low maintenance and a long troublefree life.

The perfect combination of mirror/reflector and lightsource is determined through advanced computer models.

Instead of aluminium reflectors, often used in conventional searchlights, IMAX uses brilliant mirror/reflectors, heat resistant, made of superclear glass to achieve the maximum reflectivity of 92%!! A clever ringfilter prevents glare and straylight.

Every part of the IMAX Searchlight is of course protected against the environmental circumstances at sea.

IMAX mirror/reflectors maintain their superior brilliance during many years.

The IMAX Marine type pan and tilt unit has the following features: SS-shafting, strong gears, sealing to IP66.

The reinforced housing is protected by a heavy layer of powder coating.

The controlpanel containing the 8-position joystick is designed for flushfitting in the ship's bridge console.

IMAX LIGHTENS YOUR WORK.



CROSS SECTION

IM350 RC

IMAX SEARCHLIGHTS

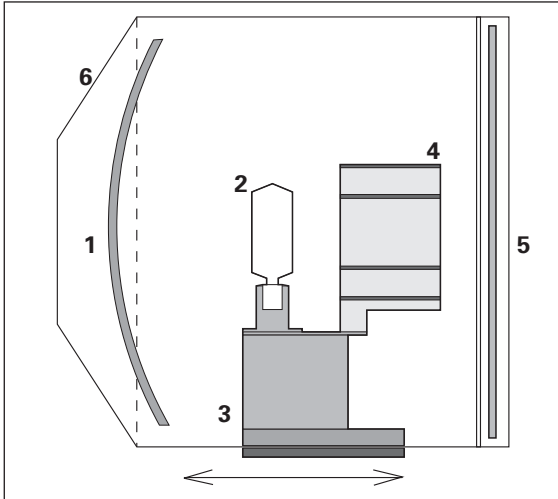

- 1 Large diameter parabolic reflector, tuned to its associated lightsource. Mirror is heat resistant.
- 2 Lightsource selected on maximum luminous flux.
- 3 Adjustable focus.
- 4 Ringfilter preventing glare and straylight.
- 5 Toughened frontglass.
- 6 Stainless steel housing and components.

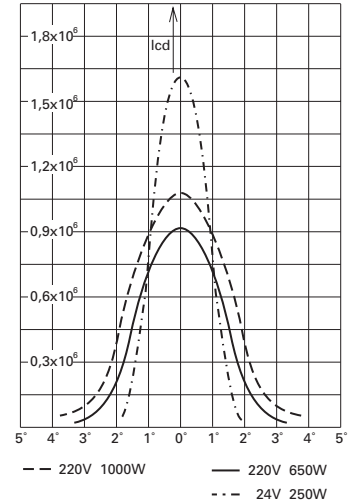

DIMENSIONS

all dimensions in mm.

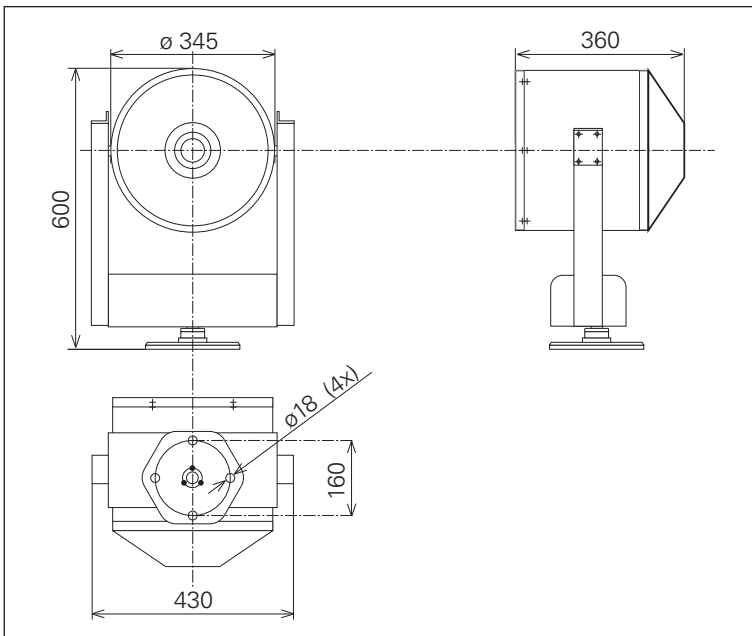

MOTOR UNIT SPECIFICATIONS

- Pan movement:** 350°
Tilt movement: +20° to -60°
Pan speed: 7.5°/sec
Tilt speed: 3°/sec
Operating temp.: -30° C to +70° C
Standard: Thermocontrolled heater
Options: Position indicator, return to datum

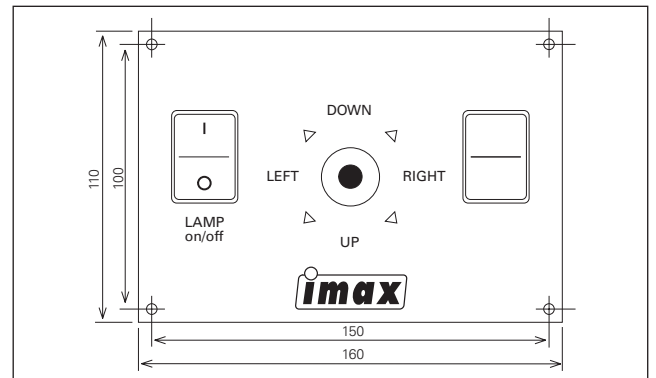

SPECIFICATIONS

Model	Voltage	Watts	PBCP (measured) Candela x 1000	Range in meters (L)	Divergence (α)	Illuminated Area at target/1 lux (T)
IM350 RC	24	250	1.576	1.273	4°	$\varnothing 90$ m
	220	650	916	957	6°	$\varnothing 100$ m
	220	1000	1.088	1.043	6°	$\varnothing 110$ m

Model	Weight
IM350 RC	21.5 kgs

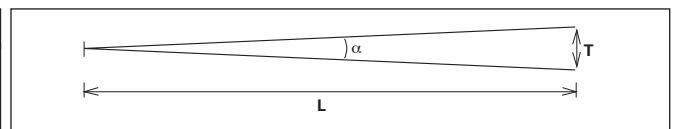

your supplier:



Hilversum - Holland